

Spring check valves TIGER

Spring valve

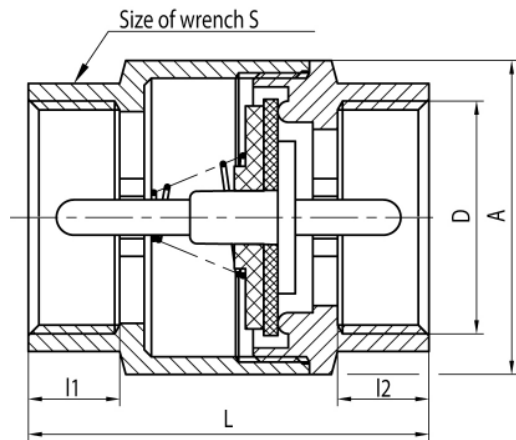

DN	Code	Dimensions							EAN13
		Size	D	A	L	l1	l2	S	
15	1900000	1/2"	G1/2	33	45	11	11	25	5907451927366
20	1900010	3/4"	G3/4	38	48	13	12	31	5907451927373
25	1900020	1"	G1	44	57	13	13	38	5907451927380
32	1900030	1 1/4"	G1 1/4	59	66,5	19	15	46	5907451908907
40	1900040	1 1/2"	G1 1/2	68,5	68	18,5	16	52	5907451908914
50	1900050	2"	G2	82,5	78	19	16,5	65	5907451908921

Product usage:

For use in plumbing and central heating systems where the heating medium is water

Type:

Spring check valves

Guarantee:

25-year

Technical data/Operating parameters:

Max pressure: 1,0 MPa,
Max temperature: 100°C

Used materials:

body, nut: brass;
spring: stainless steel;
disc with guide: polyacetal (POM);
valve disc seal: rubber EPDM

Finish:

body: brass